

Specifiche serie PA/2ST

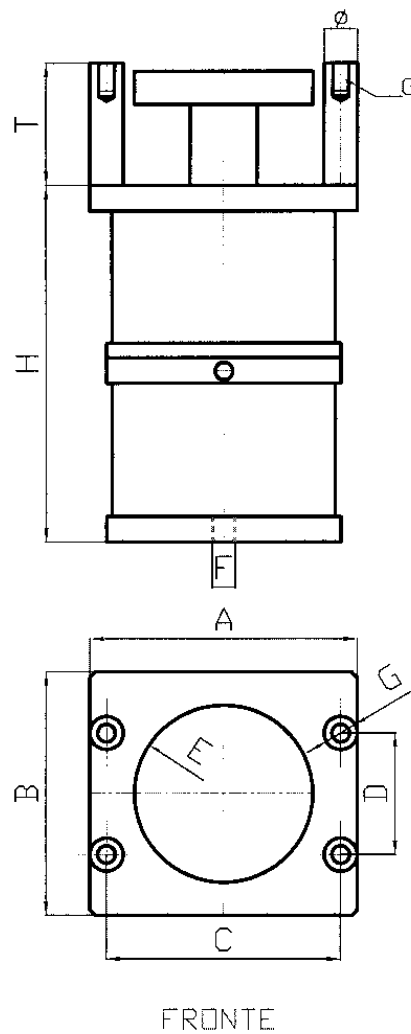

SÉRIE	POUSSÉE KN	COURSE mm	Mesures de Dimensions									
			A	B	C	D	E	F	G	H	T	Ø
2	20	60	250	220	210	110	200	1"	M18	330	110	30
3	30	60	250	220	210	110	200	1"	M18	330	110	30
5	50	60	340	250	290	165	280	1"	M18	330	110	30
7	70	80	350	310	290	165	320	1"	M24	400	140	40
10	100	80	350	350	290	165	320	1"	M24	400	140	40
12	120	100	400	400	340	340	340	1"-	M24	440	160	40
15	150	100	550	550	500	460	340	1"1/2	M30	490	180	50
20	200	100	550	550	500	460	340	1"1/2	M30	490	180	50